

## STATIONARY CONCRETE PUMP HPC 1410-817 IF8

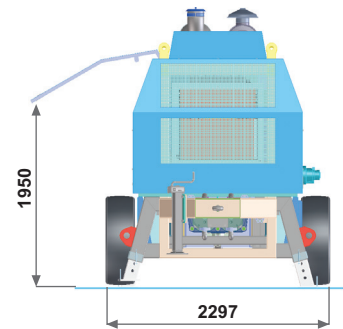

### Dimensions and performance diagrams



Pump Pressure

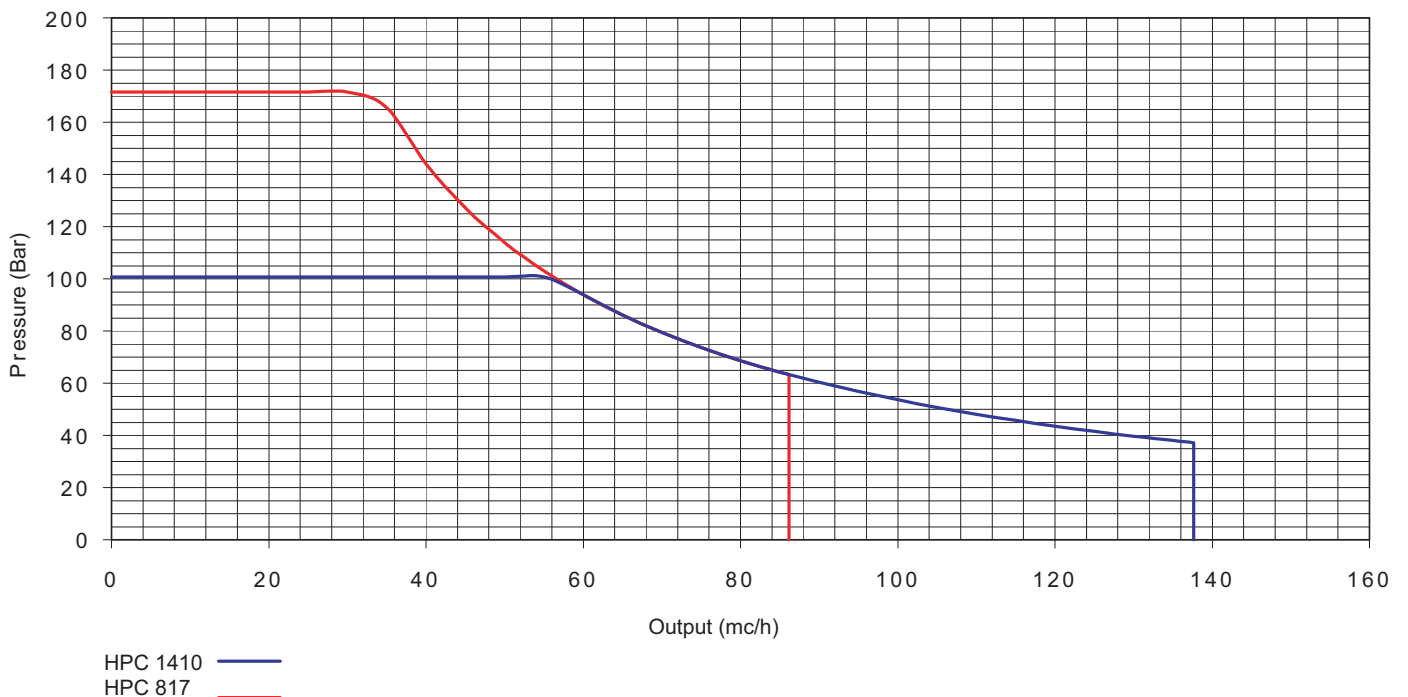

# STATIONARY CONCRETE PUMP HPC 1410-817 IF8

## Main features

- HPG pumping unit in "close loop" and reverse flow for high performances, high pressures and output, silent and regular functioning, high reliability and simply maintenance
- "S" shaped valve, in wear-resistant casting iron and variable-thickness walls, completely detachable directly from the hopper
- Wear ring mounted between the eye-plate and the valve, for a perfect seal, assuring the stiff concrete pumping
- Cifa automatic wear ring compensation, avoiding annoying adjustment
- Axial piston main pump with variable capacity and constant power; gear pump for auxiliary services
- Main power source consisting of a separate 190 kW Deutz engine
- Electronic control and visualization system for the main functioning parameters of Diesel engine (Deutz Display DED)
- Hydraulic circuit presetted for a quick changeover from low pressure feeding (HPC 1410) and high pressure feeding (HPC 817)
- Rigid mono-axle trailer with self-supporting trestle frame with four manual adjustable outriggers and two rubber wheels
- High resistance drawbar, with new Cifa system for heights adjustment in order to make easier hooking and transport operations

## Standard equipment

- Deutz engine 6 cylinders Turbo 190 kW water cooling (Step3)
- Electronic control system for the auxiliary engine (Deutz Display DED)
- Electric vibrator on the hopper grid
- Hydraulically driven water pump (70 l/min- 20 bar)
- Quick joint washing nozzle with 10 m length hose
- Greasing electric pump with proof tank
- Control panel with all the functions
- Alternator and batteries
- Electronic meter
- Diesel tank, capacity 150 l
- Water tank, capacity max 200 l
- Acoustic signal for engine breakdown
- Concrete outlet piping with bend and counterbend, OR joints + reduction device up to 5"
- High pressure outlet pipe and joints 6"
- Concrete flow rate regulator on board
- Tool box + manual lubrication pump + set of tools
- One colour painting
- Radio Remote control
- Hydraulically controlled air compressor, bicilindrical, two-stage, with accessories, stopballs cage and stub pipe

## Optional

- Stopballs cage
- Air-water cleaning stub pipe

## Technical data

Model		HPC 1410 IF8	HPC 817 IF8
Drive power	kW	190	190
Max. theoretical output	m <sup>3</sup> /h	136	80
Max. pressure on concrete	bar	101	172
Max. number of cycles per minute		36	21
Concrete cylinders (diam. x stroke)	mm	200X2000	200X2000
Concrete hopper capacity	it.	650	650
Rod side drive <input type="checkbox"/> / Piston side drive <input checked="" type="checkbox"/>		<input type="checkbox"/>	<input checked="" type="checkbox"/>

Technical data and characteristics subject to modifications without notice

